

This article was downloaded by:

On: 23 January 2011

Access details: *Access Details: Free Access*

Publisher *Taylor & Francis*

Informa Ltd Registered in England and Wales Registered Number: 1072954 Registered office: Mortimer House, 37-41 Mortimer Street, London W1T 3JH, UK



Journal of Coordination Chemistry

Publication details, including instructions for authors and subscription information:

<http://www.informaworld.com/smpp/title~content=t713455674>

Synthesis and crystal structures of one-dimensional ClO bridged coordination polymers: $\{[\text{Cu}(\text{Bpy})_2(\mu_2\text{-ClO}_4)]\cdot\text{ClO}_4\}_{n}$ and $\{[\text{Cu}_2(\text{L-arg})_2(\text{Bpy})_2(\mu_2\text{-ClO}_4)_2]\cdot 2\text{ClO}_4\cdot 4\text{H}_2\text{O}\}_{n}$

Xiaohua Zhou^a; Chi Yang^b; Xueyi Le^a; Shi Chen^a; Jiezhen Liu^a; Zhijun Huang^a

^a Department of Applied Chemistry, College of Sciences, South-China Agricultural University, Guangzhou, P.R. China ^b Faculty of Light Industry and Chemical Engineering, Guangdong University of Technology, Guangzhou 510090, P.R. China

To cite this Article Zhou, Xiaohua, Yang, Chi, Le, Xueyi, Chen, Shi, Liu, Jiezhen and Huang, Zhijun (2004) 'Synthesis and crystal structures of one-dimensional ClO bridged coordination polymers: $\{[\text{Cu}(\text{Bpy})_2(\mu_2\text{-ClO}_4)]\cdot\text{ClO}_4\}_{n}$ and $\{[\text{Cu}_2(\text{L-arg})_2(\text{Bpy})_2(\mu_2\text{-ClO}_4)_2]\cdot 2\text{ClO}_4\cdot 4\text{H}_2\text{O}\}_{n}$ ', *Journal of Coordination Chemistry*, 57: 5, 401 – 409

To link to this Article: DOI: 10.1080/00958970410001689832

URL: <http://dx.doi.org/10.1080/00958970410001689832>

PLEASE SCROLL DOWN FOR ARTICLE

Full terms and conditions of use: <http://www.informaworld.com/terms-and-conditions-of-access.pdf>

This article may be used for research, teaching and private study purposes. Any substantial or systematic reproduction, re-distribution, re-selling, loan or sub-licensing, systematic supply or distribution in any form to anyone is expressly forbidden.

The publisher does not give any warranty express or implied or make any representation that the contents will be complete or accurate or up to date. The accuracy of any instructions, formulae and drug doses should be independently verified with primary sources. The publisher shall not be liable for any loss, actions, claims, proceedings, demand or costs or damages whatsoever or howsoever caused arising directly or indirectly in connection with or arising out of the use of this material.

**SYNTHESIS AND CRYSTAL STRUCTURES OF
ONE-DIMENSIONAL ClO_4^- BRIDGED
COORDINATION POLYMERS:
 $\{[\text{Cu}(\text{Bpy})_2(\mu_2\text{-ClO}_4)] \cdot \text{ClO}_4\}_n$ AND
 $\{[\text{Cu}_2(\text{L-arg})_2(\text{Bpy})_2(\mu_2\text{-ClO}_4)_2] \cdot 2\text{ClO}_4 \cdot 4\text{H}_2\text{O}\}_n$**

XIAOHUA ZHOU^a, CHI YANG^b, XUEYI LE^{a,*}, SHI CHEN^a,
JIEZHEN LIU^a and ZHIJUN HUANG^a

^aDepartment of Applied Chemistry, College of Sciences, South-China Agricultural University, Guangzhou, 510642, P.R. China; ^bFaculty of Light Industry and Chemical Engineering, Guangdong University of Technology, Guangzhou 510090, P.R. China

(Received 7 July 2003; Revised 18 December 2003; In final form 5 March 2004)

The synthesis, structural and spectroscopic characterization of two supramolecular copper(II)-2,2'-bpy complexes of formulas $\{[\text{Cu}(\text{Bpy})_2(\mu_2\text{-ClO}_4)] \cdot \text{ClO}_4\}_n$ (1) and $\{[\text{Cu}_2(\text{L-Arg})_2(\text{Bpy})_2(\mu_2\text{-ClO}_4)_2] \cdot 2\text{ClO}_4 \cdot 4\text{H}_2\text{O}\}_n$ (2) (L-Arg = L-argininate; Bpy = 2,2'-bipyridine) are described. The two complexes have a one-dimensional supramolecular long chain structure, due to the μ_2 -perchlorate ligand between copper ions with a distorted-octahedral geometry. Crystal data of complex (2): triclinic, space group $P\bar{1}$, $a = 10.359(6) \text{ \AA}$, $b = 14.284(8) \text{ \AA}$, $c = 18.376(10) \text{ \AA}$, $\alpha = 112.192(10)^\circ$, $\beta = 96.142(9)^\circ$, $\gamma = 97.112(10)^\circ$, $V = 2463(2) \text{ \AA}^3$, $Z = 2$, $D_c = 1.696 \text{ g/cm}^3$, $\mu = 1.176 \text{ mm}^{-1}$, $F(000) = 1292$, $R_1 = 0.1234$ for 14735 observed reflections. Spectroscopic (IR and UV-Vis) properties of the complexes are in agreement with the crystal structures of the complexes. CCDC: 213581, 213582.

Keywords: Copper(II) complex; L-Arginine; 2,2'-Bipyridine; One-dimensional supramolecular chain; Crystal structure

INTRODUCTION

Crystal engineering of supramolecular architectures sustained by coordinate covalent bonds or non-covalent intermolecular forces represents a rapidly expanding field that offers potential for the development of new types of functional solids [1,2]. Controlling the structure is one of the main objects of supramolecular research, therefore the selection of the chemical structure of ligands and the coordination geometry of metal ions is key to constructing a coordination polymer [3,4]. A large number of one-

*Corresponding author. E-mail: lexyc@scau.edu.cn

two- and three-dimensional coordination polymer frameworks have already been generated with bridged-organic ligands by self-assembly [5–9]. Inorganic anions, including CN^- , $\text{C}_2\text{O}_4^{2-}$, NO_3^- , CO_3^{2-} , SO_4^{2-} , etc., have also been used as bridges in designing coordination polymers [10–15]. However, weakly coordinating perchlorate is a poor bridging ligand to construct polymer networks [13,15,16]. In the present paper, we report two one-dimensional ClO_4^- bridged coordination polymers of $\{[\text{Cu}(\text{Bpy})_2(\mu_2\text{-ClO}_4)]\cdot\text{ClO}_4\}_n$ (**1**) and $\{[\text{Cu}_2(\text{L-arg})_2(\text{Bpy})_2(\mu_2\text{-ClO}_4)_2]\cdot 2\text{ClO}_4\cdot 4\text{H}_2\text{O}\}_n$ (**2**) (where L-Arg = L-argininate; Bpy = 2,2'-bipyridine). The structures of the polymers have been characterized by elemental analysis, molar conductivity, spectroscopy and X-ray diffraction methods.

EXPERIMENTAL

Synthesis of $\{[\text{Cu}(\text{Bpy})_2(\mu_2\text{-ClO}_4)]\cdot\text{ClO}_4\}_n$ (**1**)

A solution of $\text{Cu}(\text{ClO}_4)_2\cdot 6\text{H}_2\text{O}$ (0.5 mmol) and 2,2'-bipyridine (0.5 mmol) in 25 mL of warm 40% (V/V) ethanol-water solution was stirred at 40–50°C for 30 min. To this solution an aqueous solution of L-alanine (L-Ala) (1.0 mmol) was added. The pH of the mixture was adjusted to about 5 with dilute HClO_4 solution. The resulting solution was allowed to stand in a refrigerator (4°C). After two weeks the dark-blue slender crystals were collected by filtration and washed with cold ethanol and air-dried. (51% yield) Anal. Calcd. for $\text{C}_{20}\text{H}_{16}\text{Cl}_2\text{N}_4\text{O}_8\text{Cu}$ (%): C, 41.75; H, 2.78; N, 9.74; Found: C, 41.56; H, 2.71; N, 9.80.

Synthesis of $\{[\text{Cu}_2(\text{L-arg})_2(2,2'\text{-Bpy})_2(\mu_2\text{-ClO}_4)_2]\cdot 2\text{ClO}_4\cdot 4\text{H}_2\text{O}\}_n$ (**2**)

Complex **2** was prepared by dissolving $\text{Cu}(\text{ClO}_4)_2\cdot 6\text{H}_2\text{O}$ (0.5 mmol) and 2,2'-bipyridine (0.5 mmol) in 25 mL of warm 30% (V/V) ethanol-water solution with stirring at 40–50°C for 30 min. To this solution an aqueous solution of L-arginine (0.5 mmol) was added dropwise. The pH of the mixture was adjusted to about 6 with dilute HClO_4 solution. After filtration the filtrate was allowed to stand in a refrigerator (4°C). After three weeks, the dark-blue slender crystals were obtained. (63% yield) Anal. Calcd. for $\text{C}_{32}\text{H}_{52}\text{Cl}_4\text{N}_{12}\text{O}_{24}\text{Cu}_2$ (%): C, 30.53; H, 4.13; N, 13.36; Found: C, 30.65; H, 4.20; N, 13.32.

Physical Measurements

The infrared absorption spectra in KBr discs were recorded in the 400–4000 cm^{-1} range on a Nicolet 170SX spectrophotometer. The elemental analyses (carbon, nitrogen and hydrogen) were performed on a Pekin-Elmer 240 microanalyzer. Electronic absorption spectra were measured in water on a Shimadzu UV-260 spectrophotometer at room temperature. Molar conductivities were carried out in acetonitrile using a DDS-11A conductivity gauge.

Infrared Absorption Spectra

For complexes **1** and **2**, the bands at 1580 cm^{-1} , from Bpy rings, are of weaker intensity than free Bpy, and the $\delta_{\text{C-H}}$ ($770, 630\text{ cm}^{-1}$) of Bpy are shifted to lower wave numbers, confirming coordination of Bpy nitrogen atoms to the Cu(II) [17–19]. The strong peak of ClO_4^- at 1060 cm^{-1} of the two complexes is split, due to the lowered symmetry of the coordinated ClO_4^- [15].

The complex **2** has strong and broad bands at $3437, 3314, \text{ and } 3206\text{ cm}^{-1}$, which are mostly ascribed to the stretching vibration of uncoordinated terminal amine groups (3437 cm^{-1}) and coordinated $\alpha\text{-NH}_2$ of L-Arg $\nu_{\text{NH}}^{\text{as}} = 3314\text{ cm}^{-1}$, $\nu_{\text{NH}}^{\text{s}} = 3206\text{ cm}^{-1}$ [17–22]. The absence of any bands in the region $1750\text{--}1700\text{ cm}^{-1}$ in the IR spectrum of the isolated complex suggests coordination of the COO^- group of L-Arginine to the metal ion. The bands at 1644 and 1388 cm^{-1} can be attributed, respectively, to the antisymmetric ($\nu_{\text{as, COO}}$) and symmetric ($\nu_{\text{s, COO}}$) stretching vibrations of the coordinated carboxylate group. The $\Delta\nu_{\text{COO}}$ ($\nu_{\text{as, COO}} - \nu_{\text{s, COO}} = 256\text{ cm}^{-1}$) between the two bands shows that the carboxylate is monodentate [23].

From the above assignment, one can deduce that the L-Arginine is coordinated to the metal ion as a bidentate N,O-ligand, the Bpy as a bidentate N,N-ligand, and ClO_4^- as a ligand, which is in agreement with the results by X-ray diffraction.

Electronic Absorption Spectra

The electronic absorption spectra of complexes **1** and **2** in the aqueous solution present four important absorption bands, in which the bands of complex **1** [207.2 nm ($\epsilon = 22480\text{ L mol}^{-1}\text{ cm}^{-1}$), 224.8 nm ($\epsilon = 36840\text{ L mol}^{-1}\text{ cm}^{-1}$) and 272.0 nm ($\epsilon = 37110\text{ L mol}^{-1}\text{ cm}^{-1}$)] and the bands of complex **2** [208.8 nm ($\epsilon = 21600\text{ L mol}^{-1}\text{ cm}^{-1}$), 224.8 nm ($\epsilon = 17600\text{ L mol}^{-1}\text{ cm}^{-1}$) and 300.8 nm ($\epsilon = 26700\text{ L mol}^{-1}\text{ cm}^{-1}$)] can be attributed to the $\pi \rightarrow \pi^*$ transitions of the Bpy ligand, and the broad weak absorption band of complex **1** at 610 nm ($\epsilon = 194\text{ L mol}^{-1}\text{ cm}^{-1}$) and complex **2** at 633 nm ($\epsilon = 122\text{ L mol}^{-1}\text{ cm}^{-1}$) to the $d \rightarrow d$ transition of the central Cu^{2+} ion, which is similar to the related aromatic amine- Cu^{2+} -amino acid complexes [17–22].

X-ray Structural Determination of the Complexes

Crystal data and experimental details of data collection and refinement for the complexes are listed in Table I.

A single crystal sample was used for structural determination on a Bruker Smart 1K CCD system diffractometer with graphite monochromated Mo- $K\alpha$ radiation at $\lambda = 0.71073\text{ \AA}$. The SMART program was applied to search for diffraction peaks to determine cell parameters, and the collected data were reduced by using SAINT + program [24]. Absorption correction was carried out using the Siemens Area Detector ABSorption (SADABS) program. The structure was solved by direct and Fourier methods using the SHELXS-97 program [25], and refinement on F^2 was performed using the SHELXS-97 program [26] by full-matrix least-squares with positional and anisotropic thermal parameters for all non-hydrogen atoms. All hydrogen atoms were placed in calculated positions. Atomic scattering factors were taken from the International Tables for X-ray crystallography [27]. Fractional atomic coordinates

TABLE I Crystallographic data for the complexes $\{[\text{Cu}(\text{Bpy})_2(\mu_2\text{-ClO}_4)] \cdot \text{ClO}_4\}_n$ (**1**) and $\{[\text{Cu}_2(\text{L-arg})_2(\text{Bpy})_2(\mu_2\text{-ClO}_4)_2] \cdot 2\text{ClO}_4 \cdot 4\text{H}_2\text{O}\}_n$ (**2**)

	Complex 1	Complex 2
Formula	$\text{C}_{20}\text{H}_{16}\text{Cl}_2\text{CuN}_4\text{O}_8$	$\text{C}_{32}\text{H}_{52}\text{Cl}_4\text{Cu}_2\text{N}_{12}\text{O}_{24}$
<i>M</i>	574.82	1257.74
Color	dark blue	dark blue
Crystal size (mm)	$0.50 \times 0.42 \times 0.08$	$0.50 \times 0.18 \times 0.10$
Crystal system	triclinic	triclinic
Space group	<i>P1</i>	<i>P1</i>
Unit cell dimensions	$a = 7.416(5) \text{ \AA}$, $\alpha = 110.139(5)^\circ$ $b = 11.259(5) \text{ \AA}$, $\beta = 96.235(5)^\circ$ $c = 14.888(5) \text{ \AA}$, $\gamma = 99.347(5)^\circ$	$a = 10.359(6) \text{ \AA}$, $\alpha = 112.192(10)^\circ$ $b = 14.284(8) \text{ \AA}$, $\beta = 96.142(9)^\circ$ $c = 18.376(10) \text{ \AA}$, $\gamma = 97.112(10)^\circ$
Volume (\AA^3)	1133.3(10)	2463(2)
<i>Z</i>	2	2
<i>D_c</i> (g/cm^3)	1.946	1.696
μ (mm^{-1})	1.277	1.176
<i>F</i> (000)	678	1292
Temperature (K)	293(2)	293(2)
θ range for data collection	1.48 to 27.15°	1.21 to 27.10°
Range of <i>h, k, l</i>	$-9 \leq h \leq 9$, $-13 \leq k \leq 14$, $-19 \leq l \leq 11$	$-13 \leq h \leq 13$, $-13 \leq k \leq 10$, $-23 \leq l \leq -19$
Reflections measured	6522	14735
Independent reflections	4753 ($R_{\text{int}} = 0.0291$)	10498 ($R_{\text{int}} = 0.0208$)
Completeness to θ	94.4% ($\theta = 27.15^\circ$)	95.8% ($\theta = 27.10^\circ$)
Absorption correction	None	None
Refinement method	full-matrix least-squares on F^2	full-matrix least-squares on F^2
Data/restraints/parameters	4753/0/316	10498/0/672
Goodness of fit on F^2	1.027	1.103
Final <i>R</i> indices [$I > 2\sigma(I)$]	$R_1 = 0.0713$, $wR_2 = 0.1263$,	$R_1 = 0.0929$, $wR_2 = 0.2173$
<i>R</i> indices (all data)	$R_1 = 0.090$, $wR_2 = 0.1442$	$R_1 = 0.1234$, $wR_2 = 0.2349$
Max., Min. height in final ΔF map (e/\AA^3)	1.266, -0.780	1.716, -1.020

and equivalent isotropic thermal parameters for non-hydrogen atoms are listed in Table II. The selected bond lengths and angles are collected in Table III.

RESULTS AND DISCUSSION

Elemental analyses of the complexes **1** and **2** are in agreement with the following formulas: $\{[\text{Cu}(\text{Bpy})_2(\mu_2\text{-ClO}_4)] \cdot \text{ClO}_4\}_n$ (**1**) and $\{[\text{Cu}_2(\text{L-Arg})_2(\text{Bpy})_2(\mu_2\text{-ClO}_4)_2] \cdot 2\text{ClO}_4 \cdot 4\text{H}_2\text{O}\}_n$ (**2**). The complex **1** was accidentally obtained when we attempted to synthesize supramolecular complex of copper(II) with L-Ala and Bpy, like complex **2**, by the reactions of $\text{Cu}(\text{ClO}_4)_2 \cdot 6\text{H}_2\text{O}$ with Bpy and L-Ala (L-Ala = L-alanate), but the anticipated complex was not obtained. The molecular structure of complex **1** has been reported by J. Foley and X. K. Yao [15], but the different synthesis, some unknown properties (solubility and molar conductivity) and crystal packing figure of the complex are given here.

The two complexes are soluble in warm water, methanol, ethanol and acetonitrile, but not in ether and other weak-polarity organic solvents. Molar conductivity for complexes **1** and **2** in acetonitrile at $10^{-3} \text{ mol L}^{-1}$, $\Lambda_m = 141.6$ and $305.2 \text{ S cm}^2 \text{ mol}^{-1}$ respectively, would give credence to this idea, the complexes belonged to electrolytes of 1:1 and 1:2 types, respectively [28].

TABLE II Fractional atomic coordinates($\times 10^4 \text{\AA}$) and equivalent isotropic displacement parameters $U(eq)$ ($\times 10^3 \text{\AA}^2$) for complex **2**

Atom	<i>x</i>	<i>y</i>	<i>z</i>	<i>U(eq)</i>
C(1)	2790(7)	1379(6)	860(5)	52(2)
C(2)	1997(8)	886(6)	106(5)	59(2)
C(3)	2589(9)	620(6)	550(5)	62(2)
C(4)	3949(8)	845(6)	-454(4)	52(2)
C(5)	4692(7)	1331(5)	297(4)	40(2)
C(6)	6147(7)	1605(5)	462(4)	41(2)
C(7)	6933(8)	1413(6)	-108(5)	56(2)
C(8)	8270(9)	1703(7)	111(5)	66(2)
C(9)	8813(8)	2160(7)	918(5)	63(2)
C(10)	7976(8)	2314(6)	1455(5)	55(2)
C(11)	6214(7)	3137(5)	3603(4)	44(2)
C(12)	4774(7)	3100(8)	3548(4)	72(3)
C(13)	4155(11)	3423(13)	4206(6)	135(7)
C(14)	2768(9)	3434(8)	4233(5)	74(3)
C(15)	2355(9)	3781(9)	4998(5)	80(3)
C(16)	372(9)	4179(7)	5572(5)	59(2)
C(1A)	2521(9)	6539(7)	1173(5)	65(2)
C(2A)	1658(10)	6059(8)	466(6)	78(3)
C(3A)	2162(12)	5772(8)	-243(6)	87(3)
C(4A)	3491(11)	5966(7)	-219(6)	75(3)
C(5A)	4304(8)	6446(6)	514(5)	53(2)
C(6A)	5767(9)	6705(6)	596(4)	52(2)
C(7A)	6466(9)	6471(7)	-27(5)	61(2)
C(8A)	7820(10)	6777(8)	144(6)	74(3)
C(9A)	8432(10)	7359(8)	915(6)	71(2)
C(10A)	7677(9)	7581(7)	1510(5)	63(2)
C(11A)	6375(7)	8044(6)	3739(4)	48(2)
C(12A)	4937(8)	7905(9)	3806(5)	76(3)
C(13A)	4467(12)	8206(19)	4421(7)	242(15)
C(14A)	3121(10)	8041(10)	4629(7)	83(3)
C(15A)	2676(13)	8991(16)	4841(12)	147(7)
C(16A)	607(17)	8971(10)	5366(10)	110(5)
Cl(1)	5207(2)	10(2)	2585(1)	58(1)
Cl(2)	5940(2)	4969(2)	2306(1)	54(1)
Cl(3)	1575(2)	4518(2)	2306(1)	67(1)
Cl(4)	733(2)	332(2)	2180(1)	71(1)
Cu(1)	5341(1)	2262(1)	1987(1)	40(1)
Cu(2)	5220(1)	7367(1)	2180(1)	46(1)
N(1)	4090(6)	1594(4)	949(3)	43(1)
N(2)	6661(6)	2026(4)	1247(3)	43(1)
N(3)	4066(6)	2628(5)	2750(3)	44(1)
N(4)	940(7)	3747(6)	4961(4)	60(2)
N(5)	-894(7)	4136(6)	5489(4)	67(2)
N(6)	1080(7)	4710(8)	6299(4)	91(3)
N(1A)	3829(7)	6730(5)	1198(4)	50(2)
N(2A)	6368(6)	7263(5)	1361(4)	47(1)
N(3A)	4120(6)	7366(5)	3011(3)	47(1)
N(4A)	1258	8928	4895	460(30)
N(6A)	1568(13)	9266(15)	5926(18)	276(16)
N(5A)	-564(8)	8926(7)	5589(5)	80(2)
O(1)	6653(5)	2786(4)	2934(3)	51(1)
O(2)	6919(6)	3481(5)	4243(3)	71(2)
O(1W)	9244(11)	2561(12)	3461(5)	137(4)
O(1A)	6673(5)	7890(4)	3058(3)	54(1)
O(2W)	11622(11)	8228(12)	2849(8)	158(5)
O(2A)	7190(5)	8311(5)	4350(3)	70(2)
O(3W)	-564(13)	7660(30)	3353(13)	315(19)

(continued)

TABLE II Continued

Atom	<i>x</i>	<i>y</i>	<i>z</i>	<i>U</i> (eq)
O(6)	4495(9)	-998(5)	2284(5)	107(3)
O(4W)	9620(30)	6480(30)	2390(20)	390(20)
O(4)	5107(11)	542(8)	3364(4)	131(3)
O(3)	4768(8)	510(5)	2104(4)	84(2)
O(5)	6552(8)	-57(9)	2530(8)	156(5)
O(6A)	5239(8)	3958(5)	1938(4)	90(2)
O(3A)	5352(9)	5533(5)	1918(4)	95(2)
O(4A)	5896(7)	5371(6)	3121(4)	88(2)
O(5A)	7264(7)	4966(9)	2195(5)	139(4)
O(8A)	1460(30)	4844(14)	1738(10)	316(14)
O(7A)	2358(12)	5248(10)	2975(7)	202(7)
O(10A)	398(11)	4325(11)	2492(8)	212(8)
O(9A)	2069(11)	3609(8)	1991(7)	165(5)
O(9)	910(18)	-281(14)	1524(9)	295(13)
O(10)	-342(12)	72(12)	2444(6)	216(8)
O(7)	360(30)	1090(30)	2020(20)	440(20)
O(8)	1724(11)	891(14)	2716(7)	236(9)

U(eq) is defined as one third of the trace of the orthogonalized *U*_{ij} tensor.

TABLE III Selected bond lengths (Å) and angles (°) of complex 2

Cu(1)–O(1)	1.922(5)	Cu(1)–N(1)	2.005(6)
Cu(1)–N(2)	2.001(6)	Cu(1)–N(3)	1.998(6)
Cu(1)–O(3)	2.593(6)	Cu(1)–O(6A)	2.473(6)
Cu(2)–O(1A)	1.929(5)	Cu(2)–N(2A)	1.989(6)
Cu(2)–N(3A)	2.001(6)	Cu(2)–N(1A)	2.009(6)
Cu(2)–O(3A)	2.503(6)		
O(1)–Cu(1)–N(3)	84.5(2)	O(1)–Cu(1)–N(2)	94.2(2)
N(1)–Cu(1)–N(3)	100.5(2)	N(1)–Cu(1)–N(2)	81.3(2)
O(1)–Cu(1)–O(6A)	95.0(2)	N(3)–Cu(1)–O(6A)	85.1(3)
O(1)–Cu(1)–O(3)	92.0(2)	N(2)–Cu(1)–O(3)	103.8(2)
O(3)–Cu(1)–O(6A)	163.8(3)	O(1A)–Cu(2)–N(3A)	84.4(2)
O(1A)–Cu(2)–N(2A)	94.2(2)	N(1A)–Cu(2)–N(2A)	81.0(3)
N(1A)–Cu(2)–N(3A)	100.1(3)	O(1A)–Cu(2)–O(3A)	93.1(2)
N(2A)–Cu(2)–O(3A)	87.3(3)	Cl(1)–O(3)–Cu(1)	138.7(4)
Cl(2)–O(6A)–Cu(1)	138.7(4)	Cl(2)–O(3A)–Cu(2)	138.4(4)
C(15)–C(14)–C(13)	118.3(8)	C(15A)–C(14A)–C(13A)	106.7(14)
O(4)–Cl(1)–O(3)	111.3(6)	O(6)–Cl(1)–O(3)	109.3(4)
O(3)–Cl(1)–O(5)	108.1(6)	O(4A)–Cl(2)–O(3A)	112.0(5)
O(6A)–Cl(2)–O(3A)	106.4(4)	O(5A)–Cl(2)–O(3A)	110.0(6)
C(16)–N(4)–C(15)	124.6(7)	C(16A)–N(4A)–C(15A)	137.6(12)
N(3)···O(8)	3.228	N(3)···O(9A)	3.124
N(3)···O(2W)	3.018	N(3A)···O(7A)	3.311
N(4)···O(3W)	3.084	N(4)···O(1W) (<i>x</i> – 1, <i>y</i> , <i>z</i>)	2.850
N(5A)···O(2) (<i>x</i> – 1, <i>y</i> , <i>z</i>)	2.828	N(5A)···O(2A) (<i>x</i> – 1, <i>y</i> , <i>z</i>)	2.871
N(5)···O(7A) (– <i>x</i> , – <i>y</i> +1, – <i>z</i> +1)	3.227	N(5A)···O(8) (– <i>x</i> , – <i>y</i> +1, – <i>z</i> +1)	3.382
O4W···O10A (<i>x</i> +1, <i>y</i> , <i>z</i>)	3.389	O1W···O7 (<i>x</i> +1, <i>y</i> , <i>z</i>)	3.180
N(6A)···O(10) (– <i>x</i> , – <i>y</i> +1, – <i>z</i> +1)	3.237	N(6)···O(7A)	3.227
N(6)···O(10A) (– <i>x</i> , – <i>y</i> +1, – <i>z</i> +1)	2.851	N(6A)···O(5)	3.063
N(6)···O(4A) (– <i>x</i> +1, – <i>y</i> +1, – <i>z</i> +1)	3.231		

Crystal Structures

The local coordination structure and the crystal packing view of complex **2** are shown in Figs. 1 and 2. The structure of complex **2** consists of long chain cations $\{[\text{Cu}_2(\text{L-Arg})_2(\text{Bpy})_2(\text{ClO}_4)_2]^{2+}\}_\infty$, counter anions ClO_4^- and crystallized water molecules. In long chain cations each Cu atom has approximately an elongated octahedral geometry by two Bpy nitrogen atoms, one α -amino nitrogen atom and one carboxylate oxygen of L-Arg ligand in the equatorial plane, and two perchlorate oxygen atoms in the long axial positions with two Cu–O bonds significantly longer than those in the equatorial plane. The configuration of the complex is very different from the square-pyramidal or square-planar geometry of other Cu(II) complexes containing Bpy and other amino acids [29–31].

The coordinated ClO_4^- groups, as a μ_2 -bridge, interlink octahedral Cu atoms to form one-dimensional supramolecular chains with Bpy and L-Arg ligands extended outwards on two sides to form “branches” and “patches”, respectively. In each long chain there are two different Cu(II) coordination backgrounds, in which all L-Arg ligands extended to the same side of the long chain, and the coordination bond lengths and angles around Cu1 and Cu2 are not the same. [Equatorial plane: Cu1–N 2.001(6), 2.005(6), 1.998(6)Å and Cu1–O 1.922(5)Å, Cu2–N 1.989(6), 2.001(6), 2.009(6)Å, Cu2–O 1.929(5)Å; axial: Cu1–O 2.593(6), 2.473(6)Å, Cu2–O 2.503(6)Å]. In addition, N1, N2, N3, O1, and Cu(1) atoms deviate by -0.0748 , 0.0801 , 0.0741 , -0.0794 , and -0.0059 Å, respectively, from the least-squares plane ($0.9425x + 14.2731y - 7.3814z = 1.2636$) defined by the four ligating atoms O1, N1, N2 and N3, and N1A, N2A, N3A, O1A, and Cu(2) atoms deviate by 0.0094 , -0.0100 , -0.0092 , 0.0092 , and 0.0099 Å from the least-squares plane ($-2.7275x + 14.0514y - 4.5866z = 7.8541$) defined by the four ligating atoms O1A, N1A, N2A and N3A, indicating that the five atoms (O1, N1, N2, N3 and Cu1 or O1A, N1A, N2A, N3A and Cu2) are nearly coplanar.

In the crystal of complex **2**, the neighboring one-dimensional long chains are interlinked with each other by extending L-Arg branches of one chain into the L-Arg branches of an adjacent long chain to form multiple hydrogen bonds, involving the

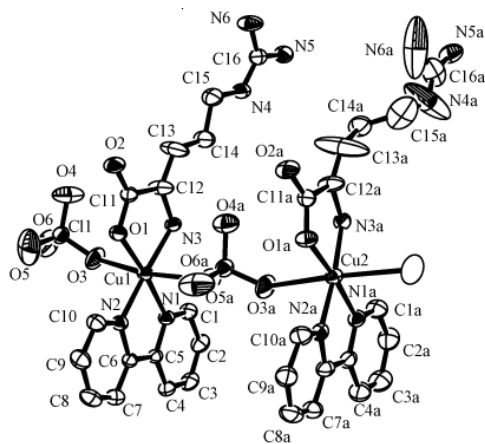

FIGURE 1 ORTEP plot showing the structure of $\{[\text{Cu}_2(\text{L-arg})_2(\text{Bpy})_2(\mu_2\text{-ClO}_4)_2]^{2+}\}_n$ cation and the atom-numbering scheme.

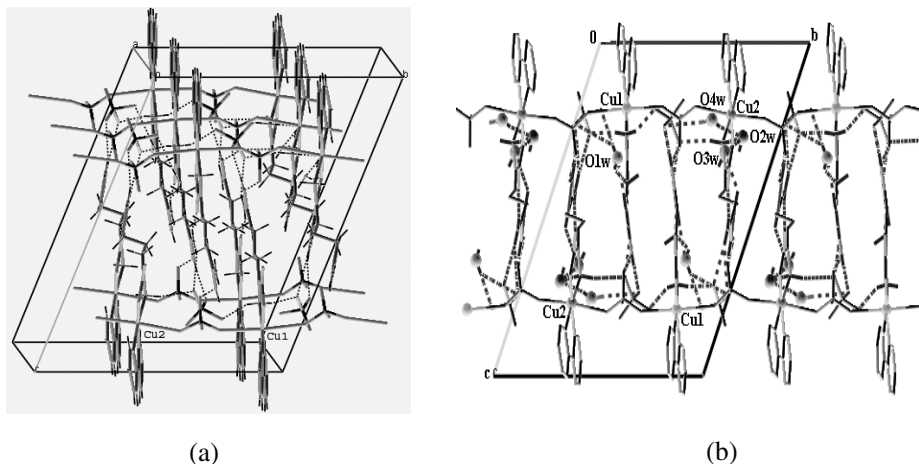

FIGURE 2 (a) The crystal packing view of complex **2** (b) The crystal packing view in *bc* plane showing ClO_4^- anion bridged chains-pairs interlinked by hydrogen bonds (dashed line) of the complex $\{[\text{Cu}_2(\text{L-arg})_2(\text{Bpy})_2(\mu_2\text{-ClO}_4)_2] \cdot 2\text{ClO}_4 \cdot 4\text{H}_2\text{O}\}_n$.

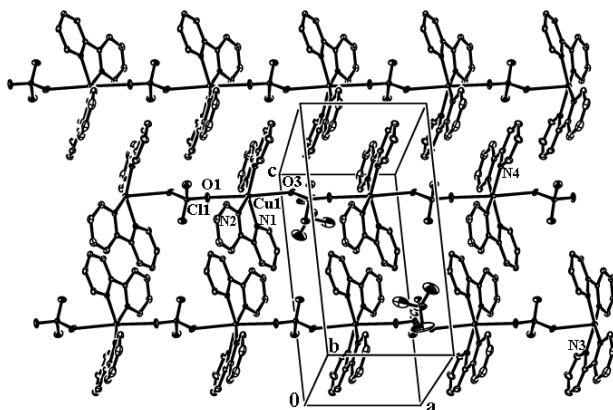

FIGURE 3 Crystal packing diagram along *b* axis showing ClO_4^- anion bridged one-dimensional chains of the complex $\{[\text{Cu}(\text{Bpy})_2(\mu_2\text{-ClO}_4)] \cdot \text{ClO}_4\}$.

four nitrogen and uncoordinated oxygen atoms of L-Arg, unbridged oxygens of $\mu_2\text{-ClO}_4^-$ ligands, counteranion ClO_4^- oxygens and crystallized water oxygen atoms. The range of hydrogen bonds is 2.828–3.231 Å; selected hydrogen bond lengths are shown in Table III. The Bpy-patches outside of the double-chains do not intercalate into the Bpy-patches of adjacent double-chains, with the distance of neighboring Bpy rings at about 7.1 Å, which indicates no $\pi \rightarrow \pi^*$ overlapping, thus a two-dimensional grid is developed. (See Fig. 2.)

The crystal structure of complex **1** consists of supramolecular long chain cations $\{[\text{Cu}(\text{Bpy})_2(\mu_2\text{-ClO}_4)]^+\}_\infty$, and counter anions ClO_4^- . In the supramolecular long chain cations, each Cu atom has approximately an elongated rhombic octahedral geometry by four Bpy nitrogen atoms in the equatorial plane and oxygen atoms of bridging ClO_4^- ligands in the long axial positions, not different from that previously

reported [15]. The crystal-packing figure of complex **1**, not previously reported [15], is shown in Fig. 3.

Although both solid polymers are formed by ClO_4^- bridges, the long Cu-O distances show the weak coordination ability of perchlorate, which is confirmed by the water-solubility and molar conductivity of the complexes.

Acknowledgment

This work was supported by the Natural Science Foundation of China (No. 20105003) and the Natural Science Foundation of Guangdong Province (No. 010338).

References

- [1] J.M. Lehn, *Supramolecular Chemistry: Concepts and Perspectives*, VCH: Weinheim, Chapter 9 (1995).
- [2] C.B. Aakeroy and K.R. Seddon, *Chem. Soc. Rev.* **397** (1993).
- [3] C.J. Jones, *Chem. Soc. Rev.* **7**, 289 (1998).
- [4] W.W. Ellis, M. Schmitz, A.A. Arif and P. Stang, *Inorg. Chem.* **39**, 2547 (2000).
- [5] D.J. Chesnut, D. Plewak and J. Zubieta, *J. Chem. Soc., Dalton Trans.* **18**, 2567 (2001).
- [6] O.M. Yaghi, H. Li and T.L. Groy, *Inorg. Chem.* **36**, 4292 (1997).
- [7] P. Ayyappan, O.R. Evans and W.B. Lin, *Inorg. Chem.* **41**(13), 3328 (2002).
- [8] D.L. Long, A.J. Blake, N.R. Champness C. Wilson and M. Schroder, *J. Am. Chem. Soc.* **123**, 3401 (2001).
- [9] H.F. Zhu, L. Li, J. Fan, W. Zhao and W.T. Sun, *Chin. J. Inorg. Chem.* **19**(1), 25 (2003).
- [10] S. Zdenek, C. Ivana and M. Jerzy, *Polyhedron* **20**(28), 3301 (2001).
- [11] H.Y. Shen, W.M. Bu, D.Z. Liao, Z.H. Jiang, S.P. Yang and G.L. Wang, *Inorg. Chem.* **39**, 2239 (2000).
- [12] D.J. Chesnut, A. Kusnetzow, R. Birge and J. Zubieta, *J. Chem. Soc., Dalton Trans.* **18**, 2581 (2001).
- [13] S.M. Partha, K.M. Tapas, M. Golam, H. Wendy and R.C. Nirmalendu, *New J. of Chem.* **25**(5), 760 (2001).
- [14] K. Kicelbick, *Acta crystallographica, Sect. E: Structure Report online* **E57**(10), m475 (2001).
URL: <http://journals.iucr.org/e/issues/2001/10/00/wn6050/wn6050.pdf>
- [15] a) J. Foley, D. Kennefick, D. Phelan, S. Tyagi and B. Hathaway, *J. Chem. Soc. Dalton Trans.* 2333 (1983)
b) X.K. Yao, H.G. Wang, D.Z. Liao, S.M. Wang and G.L. Wang, *J. Struct. Chem.* **10**, 139 (1991).
- [16] Mohamed A.S. Goher and Franz A. Mautner, *Polyhedron* **19**, 601 (2000).
- [17] X.H. Zhou, X.Y. Le and M.H. Li, *Chem. J. Chin. Univ.* **21**, 681 (2000).
- [18] X.H. Zhou, X.Y. Le and M.H. Li, *Chin. Chem. Bull.* **64**, 48 (2001).
- [19] X.Y. Le and M.L. Tong, *Chin. J. Chem.* **18**, 1023 (2002).
- [20] X.Y. Le, M.L. Tong, Y.L. Fu, L.N. Ji, *Acta Chim. Sin.* **60**, 367 (2002).
- [21] X.Y. Le, M.L. Tong, Y.L. Fu and L.N. Ji, *Chin. J. Chem.* **21**, 44 (2003).
- [22] X.Y. Le, X.H. Zhou, Z.J. Huang and X.L. Feng, *J. Coord. Chem.* **56**(10), 861 (2003).
- [23] K. Nakamoto, *Infrared and Raman Spectra of Inorganic and Coordination Compounds* (John Wiley and Sons Inc., New York, 1986), 4th Edn., p. 257.
- [24] Bruker AXS, SAINT+ version 6.0, Bruker AXS, Madison, WI, USA, 1999.
- [25] G.M. Sheldrick, SHELXS-97, *Program for X-ray Crystal Structure Determination* (Göttingen University, Germany, 1997).
- [26] G.M. Sheldrick, SHELXL-97, *Program for X-ray Crystal Structure Refinement* (Göttingen University, Germany, 1997).
- [27] A.J. Wilson, *International Tables for X-ray Crystallography*, Vol. C, Kluwer Academic Publishers, Dordrecht, 1992, Tables 6.1.1.4(p500) and 4.2.6.8 (p219), respectively.
- [28] W.J. Gear, *Coord. Chem. Rev.* **7**, 81 (1971).
- [29] G. Lantolini, L. Marcotrigiano, G.C. Menabue, M.S. Pellacani and M. Sola, *Inorg. Chem.* **24**, 3621 (1985).
- [30] X. Solans, L. Ruiz-Ramirez, A. Martinez, L. Gasoue and R. Moreno-Esparza, *Acta Cryst. C* **48**, 1785 (1992).
- [31] S. Tamotsu, M. Hideki, O. Nayumi, K. Kouji, O. Akira and Y. Osamu, *Inorg. Chem.* **36**, 576 (1997).